

**Pro AV 1600 PCI
USER MANUAL
Rev. 1.0**

FOCUS Enhancements, Inc.
1370 Dell Ave
Campbell, CA 95008
P: 408-866-8300
F: 408-866-4859
www.FOCUSinfo.com

1	INTRODUCTION.....	3
1.1	THE PRO AV 1600 FAMILY	4
1.2	OPERATIONAL SPECIFICATIONS	6
2	INSTALLATION.....	8
2.1	PRO AV 1600 PCI VERSION INSTALLATION	9
3	PRO AV 1600 CONTROLS AND ADJUSTMENTS.....	12
3.1	PRO AV 1600 INTERFACE CONTROLLABLE FUNCTIONS.....	12
3.2	INTERNAL ADJUSTMENTS	16
4	HYPERFORMANCE UTILITY SOFTWARE.....	18
4.1	HYPERFORMANCE COMPONENTS	18
	APPENDIX A - LIMITED WARRANTY.....	21
	APPENDIX B - HYPERFORMANCE UTILITY SOFTWARE LICENSE.....	22
	APPENDIX C – GENLOCK.....	23
	APPENDIX D - COMPONENT OUTPUT.....	24

1 Introduction

The FOCUS Enhancements Pro AV 1600 product family is a series of products that produce standard, recordable NTSC or PAL base band video from High-Resolution Computer Graphics devices. In addition to composite and S-video, the Pro AV 1600 has Betacam-compatible or RGB component outputs.

The Pro AV 1600 automatically senses the input resolution and frequency of the incoming Computer Graphics signal and transforms the resolution of input Computer Graphics to full screen, 24 bit color, NTSC or PAL Video. The Pro AV 1600 performs this transformation without disturbing the input Computer Graphics signal in any way; High-Resolution Computer Graphics appears on the system's computer monitor as if the Pro AV 1600 was not there.

The Pro AV 1600's output is fully broadcast compatible, and it has the ability to genlock to a reference video or black burst signal. With this feature, you can synchronize your computer to video inputs or systems. Your computer can then be used as a graphics or presentation video source. Independent adjustments allow full control over H phase and subcarrier phase.

—

1.1 The Pro AV 1600 Family

1.1.1 Board, Desktop or Rackmount

Our Pro AV 1600 family of products include internal units (PCI board) and external units. The internal units mount inside the PC and receive their electrical power from the computer. The external units are either desktop, with a wall mount transformer, or as an EIA 19 inch rack mount configuration. The Pro AV 1600 rack mount occupies a standard rack height. All Pro AV 1600-R models are capable of accepting power in the range of 95 V - 250 V, 47Hz. to 63 Hz. Throughout this document, "ProAV 1600" will refer to general family features, while "ProAV 1600 PCI" is specific

1.1.2 Compatibility

The Pro AV 1600 is compatible with IBM PC computers, MAC computers and many popular workstations. The same Desktop unit may be used with any personal computer or workstation, however the appropriate cable kits must be ordered. The Pro AV 1600 is shipped with a PC cable and a Mac Adapter Kit. Any cable or cable kit may be ordered separately. The Pro AV 1600 PCI is only compatible with IBM PC computers and its control panel runs on the Windows platform.

On PC's, the Pro AV 1600 supports VGA and super VGA devices in all VGA standard modes (640 x 480, EGA, Text and 320 x 200 modes, all 800 x 600 modes from 56 - 76 Hz Vertical Non-Interlaced, all 1024 x 768 modes from 60 - 76 Hz and all 1280 x 1024 modes from 60 - 76 Hz Vertical Non-Interlaced. The 1024 x 768 Non-Interlaced modes of the XGA-2 are also supported.

On Macs, The Pro AV 1600 supports 640 x 480, 66.7 Vertical Non-Interlaced mode (Applecolor High-Resolution RGB Monitor, often referred to as the 13" display) and the 1024 x 768, 66.7 Hz Vertical Non-Interlaced mode (AppleVideo RGB Monitor, often referred to as the 21" display).

In addition to these video formats, the Pro AV 1600 also accepts computer video in popular workstation formats (up to its 1024 x 768 limit). The Pro AV 1600 is capable of decoding a separate composite synchronization signal, as well as a composite sync signal embedded in the green signal. The correct cable kit is required for successful use with a workstation.

Accessory Items

The following items may be ordered separately as accessories:

444-5906	HD15 Male – 5 BNC Male Cable (PC)
444-5907	HD15 Female – 5 BNC Male Cable (PC)
444-5908	DB-15 Male – 5 BNC Male Cable (Mac)
444-5909	DB-15 Female – 5 BNC Male Cable (Mac)
444-5910	13W3 Male – 5 BNC Male Cable (Sun)
444-5914	5 BNC-Male – 5 BNC Male Extender Cable
3201-901	RS-232 Control Cable
444-8200	Univiewer Cable

1.2 Operational Specifications

1.2.1 Input Resolutions

All original IBM VGA Modes

640 x 480	72 Hz.	(S-VGA Vesa Spec. VS900101)
640 x 480	75 Hz.	(S-VGA Vesa Spec. VGMT)
800 x 600	56 Hz.	(S-VGA Vesa Spec. VG900601)
800 x 600	60 Hz.	(S-VGA Vesa Spec. VG900602)
800 x 600	72 Hz.	(S-VGA Vesa Spec. VS900603)
800 x 600	75 Hz.	(S-VGA Vesa Spec. VGMT)
1024 x 768	60 Hz.	(S-VGA Vesa Spec. VG901101)
1024 x 768	70 Hz.	(S-VGA Vesa Spec. VS910801)
1024 x 768	75 Hz.	(S-VGA Vesa Spec. VGMT)
1024 x 768	60-76 Hz.	(IBM XGA-2 Non-Interlaced modes) (requires 9515 or 9517 monitor)
1280 x 1024	60 Hz	(SXGA Vesa Spec. VDMTREV)
1280 x 1024	75 Hz	(SXGA Vesa Spec. VDMT75HZ)
1280 x 1024	85 Hz	(SXGA Vesa Spec. VDMTPROP)
1600 x 1200	60-85Hz	(UXGA Vesa Spec. VDMTREV)
640 x 480	66.7 Hz.	(AppleColor High-Resolution 13" RGB Monitor)
1024 x 768	60 Hz.	(AppleVideo 21" RGB Monitor)

Or any computer video resolution up to 1600x1200 at up to 120Hz.

All workstation modes in the range of 640 x 480 to 1600 x 1200

THE PRO AV 1600 DOES NOT SUPPORT INTERLACED INPUT.

1.2.2 Input Color Capability

All input formats are internally converted, and processed as 24 bit RGB signals. The Pro AV 1600 is therefore capable of handling an input color space of up to 16.8 million colors.

1.2.3 Output Resolutions

NTSC

484 displayed lines vertically

Underscan/Overscan Switch selectable

PAL

576 displayed lines vertically

Underscan/Overscan Switch selectable

1.2.4 Digital Flicker Reduction Filter

A multistage Digital Flicker Reduction Filter is a standard feature of all models of the Pro AV 1600. The Flicker Filter may be engaged at one of seven different levels or disengaged by any one of the control methods.

1.2.5 Pro AV 1600 PCI Connectors

(with reference to Pro AV 1600)

Computer Video Input	HD15 Male
Composite Video Output	Female BNC (Female RCA optionally available)
S-Video	Mini-Din 4 position female
Genlock	Female BNC (loop-through requires "T" connector)
Component	Female BNC

1.2.6 Power Consumption

Within single slot specifications

1.2.7 Physical Size

6.785"x4.2" PCI card

1.2.8 Environmental

Temperature:

Operating: 0 – 40 degrees Celsius
Non-Operating: -40 to 70 degrees Celsius

Humidity:

Operating: 15% to 80% non-condensing
Non-Operating: 10% to 95% non-condensing

Altitude:

Operating: -500 to 15000 ft. ASL
Non-Operating: -1000 to 50000 ft. ASL

Electromagnetic:

Susceptibility: EN50082-1
Radiation: CISPR 22 (1993-12), FCC Class B

2 Installation

Installation of all Pro AV 1600 PCI products is a simple and quick procedure.

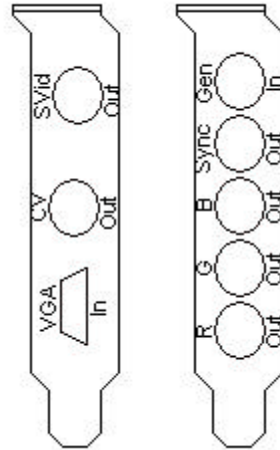

Figure 1: Pro AV 1600 PCI Card Back Plate Diagrams

2.1.0 Pro AV 1600 PCI Version

The Pro AV 1600 PCI is shipped with a Univiewer cable.

Follow these steps to install your Pro AV 1600 PCI. If you intend to use the Pro AV 1600 with Genlock or component output please see Appendix C (Genlock operation) and Appendix D (Component output) for further information on these features.

Hardware Installation

1. Turn the computer off.
2. Install the PCI card.
3. Disconnect the Computer Display from the Graphics Card on the Computer.
4. Connect the Univiewer module to the output of your computer graphics card. Connect the flying lead of the Univiewer cable to the VGA input of the Pro AV PCI card..
5. Connect your Video Device to the Composite Video and/or S-Video output connector. (You may connect both outputs simultaneously to the same or different Video Devices: Video is always available on both these outputs.)
6. Turn the computer on and run (or install) the Pro AV 1600 application software
7. From the application, set the Sync Selection to "IN= VGA SYNC". (See section 3.1.19 for additional details on Sync Selection.)
8. If everything is correctly installed, you will see your computer's normal power up sequence appearing on both the Computer Display and the Video Device.

Software Installation

SYSTEM REQUIREMENTS:

Pentium-class system with an available 32-bit PCI slot.
Windows 98, ME, NT, or 2000

INSTALLATION PACKAGE:

ProAV.inf
ProAV.sys
ProAV.cpl
ReadMe.txt

Win98(Me) Destination directories:

ProAV.sys is copied to c:\windows\system32\drivers
ProAV.cpl is copied to c:\windows\system

Win2000 Destination directories:

ProAV.sys is copied to c:\winnt\system32\drivers
ProAV.cpl is copied to c:\winnt\system32

WINDOWS 98 DRIVER INSTALLATION:

- 1) With the power off, install the Pro AV 1600 PCI card into an available PCI slot, then turn the power on.
- 2) When the Add New Hardware Wizard dialog pops up informing you that it has found a PCI Network Controller, install the CDROM with the Pro AV 1600 PCI driver software. Click on "Next".
- 3) Select the option "Search for the best driver for your device (Recommended)", and click on "Next".
- 4) Specify a search location by checking the "CD-ROM drive" box and uncheck all the others. Click on "Next".
- 5) Click on "Next" for location of driver.
- 6) If a File Not Found dialog opens up for the file ProAV.cpl, click on Browse to find the correct path, then double click on ProAV.cpl to close the Browser dialog. Click on "OK" to continue Copying Files.
- 7) Click "Finish".

WINDOWS Me DRIVER INSTALLATION:

- 1) With the power off, install the Pro AV 1600 PCI card into an available PCI slot, then turn the power on.
- 2) When the Add New Hardware Wizard dialog pops up informing you that it has found a PCI Network Controller, install the CDROM with the Pro AV 1600 PCI driver software.
- 3) Select the option "Automatic search for a better driver (Recommended)", and click on "Next".
- 4) Click "Finish".

WINDOWS 2000 /NT DRIVER INSTALLATION:

- 1) With the power off, install the Pro AV 1600 PCI card into an available PCI slot, then turn the power on.
- 2) The Found New Hardware dialog will identify a Network Controller. Install the CDROM with the Pro AV 1600 PCI driver software.
- 3) The Found New Hardware Wizard dialog will open. Click "Next".
- 4) Select the option "Search for a suitable driver for your device (recommended)", and click on "Next".
- 5) For the optional search locations, check the "CD-ROM drives" box. Uncheck all the other boxes. Click on "Next".
- 6) To install the driver Windows found, click on "Next".
- 7) When prompted by the Digital Signature Not Found dialog as to whether you want to continue the installation, click on "Yes".
- 8) Click on "Finish".

VERIFYING THE INSTALLATION:

- 1) Bring up the Control Panel (Start->Settings->Control Panel).
- 2) Confirm the driver is working properly as follows:
 - a) Double Click on the System icon.
 - b) Select the Device Manager tab.
 - c) Click on "Sound, video and game controllers."
 - d) Double Click the Pro AV 1600 PCI icon to open the

- Pro AV 1600 PCI Properties dialog.
- e) Select the General tab. The Device status should show "This device is working properly."
- 3) Run the ProAV control applet as follows:
- a) Double click on the ProAV icon.
 - b) Try the controls.

SUPPORT

Technical Support United States 408-370-9963
(M-F, 8AM-12 Noon, 1PM-5PM, PST)

Customer Support United States 800-338-3348

Web Site
www.focusinfo.com

3 Pro AV 1600 controls and adjustments

There are several parameters on the Pro AV 1600 that can be controlled through by the Pro AV 1600's control interfaces.

Additional adjustments to functions that are not likely to be accessed frequently - or are intended to be adjusted by service personnel only - are available in the form of potentiometers, variable capacitors and jumpers on the Pro AV 1600 board itself. Access to these internal adjustments requires internal access to the PC.

3.1.0 Pro AV 1600 Interface Controllable Functions

The following parameters are accessible using the Pro AV 1600's control interfaces. Each of the controls has one of three possible types of parameters associated with it, Toggle (the function is either on or off), Multiple Choice (there are several, mutually exclusive options) or Range (the parameter varies over a range of values for a particular function). Section 4 details the use of each of the Control interfaces.

3.1.1 Horizontal/Vertical Position (Range)

This control enables the user to position the converted Computer Graphics with respect to the output television. The actual functioning of this control is dependent on the state of the Zoom function. If Zoom is off, H/V Position enables minor changes in position of the full screen image. If zoom is on, H/V position functions as a pan and scroll control, positioning the input window for zooming.

3.1.2 Horizontal/Vertical Size (Range)

This control enables the user to size the converted Computer Graphics with respect to the output television. The actual functioning of this control is dependent on the state of the Zoom function. If Zoom is off, H/V Size enables minor changes in size of the full screen image. If Zoom is on, the H/V Size Control is inactive. To properly size the PC output to the television screen, follow these steps:

1. Position the under-scanned image to the top, left corner of the television screen
2. Toggle the Pro AV control panel to H,V Sizing
3. Use the IR remote control pad or arrow keys to size the screen both horizontally and vertically

3.1.3 Zoom (Toggle)

This control applies a 2X Zoom to a portion of the input Computer Graphics. The position of the window is determined by the H/V Position control.

3.1.4 UnderScan (Toggle)

This control selects whether Underscan is applied to the Television Output. An "UnderScanned" picture slightly shrinks the whole display such that information in the corners is visible. Select "UNDERSCAN" when you have text or detail oriented pictures that requires you to preserve fine detail in the corner regions of the display. An "OverScanned" picture fills the entire area of the screen, which is the natural way of presenting material in television. Select "OVERSCAN" to present photo-realistic and animation oriented material.

3.1.5 Terminate VGA (Toggle)

This control connects the Pro AV1600's 75 Ohm termination resistors onto the computer's RGB output lines. Select "TERMINATED" unless you are using the Pro AV 1600 with a pass through monitor cable (such as a HyperCable-PC, intended for use with the Pro AV CP product line).

3.1.6 Fine Genlock H Position (Range) (Not available from IR remote mouse)

This control adjusts the relative horizontal picture position of the Television Output with respect to a Reference Television signal. This control is only operational when using the Genlock capability of the Pro AV 1600.

3.1.7 Coarse Genlock H Position (Range) (Not available from IR remote mouse)

This control adjusts the relative horizontal picture position of the Television Output with respect to a Reference Television signal. This control is only operational when using the Genlock capability of the Pro AV 1600.

3.1.8 Genlock Subcarrier Phase (Range) (Not available from IR remote mouse)

This control adjusts the relative Subcarrier Phase of the Television Output with respect to a Reference Television signal. This control provides slightly more than 180 degrees of variable phase control and must be used in conjunction with the Genlock Subcarrier Phase Reverse Control to establish 360 degrees of phase control. This control is only operational when using the Genlock capability of the Pro AV 1600.

3.1.9 Genlock Subcarrier Phase Reverse (Toggle) (Not available from IR remote mouse)

This control selects 180 degrees of Television Output Subcarrier Phase shift with respect to a Reference Television signal. This control is only operational when using the Genlock capability of the Pro AV 1600.

3.1.10 Genlock Termination (Toggle) (Not available from IR remote mouse)

This control applies a 75 Ohm termination to the Genlock input. This control is always operational.

3.1.11 NTSC/PAL (Toggle) (Not available from IR remote mouse)

This control selects between PAL and NTSC operation. Set this control to PAL for European operation. Set this control to NTSC for American operation.

3.1.12 Flicker Reduction Filter (Multiple)

This control operates the Flicker Reduction Filter. Flicker filter settings from 0 (Flicker Filter is Off) to 7 (Flicker Filter is at a maximum) are available. The display will indicate "FLK FLT = #" where # is the current setting of the Flicker Filter.

3.1.13 Brightness Boost (Toggle) (Not available from IR remote mouse)

This control applies a Brightness Boost to the Television Output. Set "BRIGHT MAX" to raise the brightness of the Television Output. Set "BRIGHT NORM" to set the Television Output to regulation brightness level.

3.1.14 Freeze Frame (Toggle)

This control freezes the output video of the Pro AV 1600. Select "INPUT FROZEN" to freeze the picture. Select "INPUT LIVE" to view live input.

3.1.15 IR Remote Disable (Toggle) (Not Available from IR remote mouse)

This control disables the operation of the IR remote mouse. Select "IR ON" to enable the operation of the remote mouse. Select "IR OFF" to disable the operation of the IR Remote Mouse and prevent IR conflicts.

3.1.16 Colorbar Pattern Enable (Toggle) (Not available from the IR Remote Mouse)

This control enables the Colorbar pattern to be displayed at the television output. Use the Colorbar test pattern to test for successful connection of the Pro AV 1600 to the television device; no input source is required. Select "COLORBAR ON" to enable the color bar pattern to be displayed at the output. Select "COLORBAR OFF" for normal operation.

3.1.17 YUV /RGB Selection mechanism (Toggle) (Not available from IR remote mouse)

This control selects the color space of the component output. Select "RGB OUTPUT" for RGB appearing on the R-Y, Y and B-Y connectors respectively. Select "YUV OUTPUT" for BetaCam levels of R-Y, Y and B-Y appearing on the R-Y, Y and B-Y connectors respectively.

3.1.18 Sync Selection (Multiple) (Not available from IR remote mouse)

This control determines how the Pro AV will interpret input synchronization signals from the Computer Graphics device. Select "IN= VGA SYNC" for VGA input and other devices that provide 5 wire video signals (i. e. Red, Green, Blue, and H and V sync). Select "IN= MAC SYNC" for Macintosh input and other devices that provide 4 wire video signals (i. e. Red, Green, Blue, and a composite sync). Select "IN= GRN SYNC" for Workstation input and other devices that provide 3 wire video signals (i. e. Red, Green, Blue, with composite sync on Green).

3.1.19 Contrast (Range) (Not available from IR remote mouse)

This control enables the user to control the contrast of the output video. The relative value of contrast is indicated on a scale of 0 to 127. The default value is 62.

3.1.20 Brightness (Range) (Not available from IR remote mouse)

This control enables the user to control the brightness of the output video. The relative value of brightness is indicated on a scale of 0 to 127. The default value is 60.

3.1.21 Saturation (Range) (Not available from IR remote mouse)

This control enables the user to control the saturation of the output video. The relative value of contrast is indicated on a scale of 0 to 127. The default value is 127.

3.1.22 Save Configuration (Multiple) (Not available from IR remote mouse)

The Pro AV 1600 enables the storage of 15 user defined parameter sets of all of its control settings. (A 16th Save/Recall parameter set is automatically saved and recalled on power-up.) To save the current setting select the Save command with the + / - buttons. The next configuration to be saved will be indicated on the display. The act of pressing any one of the arrow buttons will cause the current set of parameters to be saved as "Save Set #" (where # is the # appearing on the display). The display will immediately increment to the next Save Set number. The Save feature is not available from RS-232/422 Control.

3.1.23 Recall Configuration (Multiple) (Not available from IR remote mouse)

Using the Recall Configuration feature, the user can instantly recall any previously saved Save Set. The up or down arrow keys select from previously configured Save Sets. Recall Configuration is not available from RS-232/422 Control.

3.1.24 Erase Configuration (Multiple) (Not available from IR remote mouse)

The Erase Configuration feature is the reverse of the Save Configuration. To erase the most recently saved configuration enter the Erase command with the + / - buttons. The last configuration to be saved will be indicated on the display. The act of pressing any one of the arrow buttons will cause the numbered set of parameters "Save Set #" (where # is the # appearing on the display) to be erased. The display will immediately decrement to the next Save Set number. The Erase feature is not available from RS-232/422 Control.

3.1.25 Auto Reset

This control resets the Pro AV to its default settings. Default Settings are as follows:

Function	Auto Reset Parameter Value
Horizontal/Vertical Position	Best Factory Estimate
Horizontal/Vertical Size	Best Factory Estimate
Zoom	Off
UnderScan	Overscanned
Terminate	TERMINATED
Fine Genlock H Position	Best Factory Estimate
Coarse Genlock H Position	Best Factory Estimate
Genlock Subcarrier Phase	Best Factory Estimate
Genlock Subcarrier Phase Reverse	0 degrees
Genlock Termination	Genlock input Unterminated
NTSC/PAL	as originally shipped
Sharpness	FLICKER OFF
Brightness Boost	Off
Freeze Frame	INPUT LIVE
IR Remote	Enabled
Colorbar Test Pattern	Disabled
YUV/RGB Selection	RGB OUTPUT
Sync Selection	IN = VGA SYNC
Recall Configurations	All are preserved

3.2 Internal Adjustments

The following adjustments are internal adjustments, done on the PCI card itself. These controls require the user to access the Pro AV 1600 PCI card (on a PCI extender card, for example) and make the indicated adjustment with an adjustment tool.

3.2.1 Color Burst Level VR1

This potentiometer adjusts the amplitude of the Color Burst.

3.2.2 Output NTSC Pedestal VR2

This potentiometer adjusts the level of the NTSC Pedestal.

3.2.3 RGB Output Level VR9

This potentiometer adjusts the RGB Output Level

3.2.4 FSC-403 Reference Voltage VR10

This potentiometer adjusts the Voltage Reference on the FSC-403 chip.

3.2.5 Sync on Y output Insertion JP6

This jumper determines whether composite sync is inserted on the Y output. Connect the 2 posts of this jumper together to produce sync on the Y output. Sync is always available on the dedicated component sync output connector. The factory default is Sync on Y selected (Jumper JP6 installed).

3.2.6 Pal GenLock Trim Cap C6

Adjusts PAL color frequency

3.2.7 NTSC Genlock Trim Cap C11

Adjusts NTSC color frequency

Figure 2: Adjustments and Jumpers

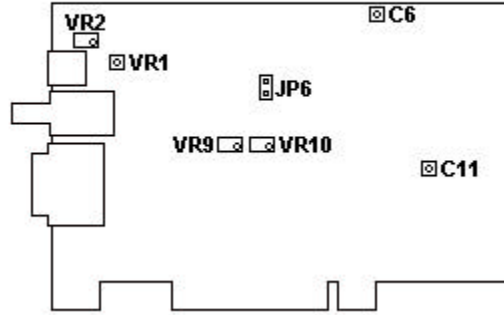

4 Hyperformance Utility Software

A DOS test program for IBM PCs, entitled Hyperformance, can be downloaded from the FOCUS Enhancements web site. If you would like to obtain a copy of Hyperformance, please log onto www.focusinfo.com. The Hyperformance software is available at the downloads page which is in the Tech Support section of the website.

4.1.0 Hyperformance Components

Hyperformance Software consists of a DOS application program with some sample images.

The release contains the following files:

Hyperformance Test Software Disk

HYPER.EXE	Hyperformance Test Software
PICTURE8.PCX	A 256 color image
PICTURE4.PCX	A 16 color image

4.1.1 Installing and Running Hyperformance Tests Software

To install the software, copy the contents of the Hyperformance PC Test Software diskette to your hard disk, as follows:

```
COPY A:*. * C: or B:*. * C:
```

This command should copy HYPER.EXE, PICTURE8.PCX, and PICTURE4.PCX to your hard disk.

To execute the program, type "HYPER".

4.1.2 The Main Menu

Upon execution, the utility software displays the following menu:

```
PRO AV UTILITY SOFTWARE
1      Text Mode 720 x 400 (Mode 3 hex)
2      16 color 640 x 350 (Mode 10 hex)
3      16 color 640 x 480 (Mode 12 hex)
4      256 color 320 x 200 (Mode 13 hex)
5      16 color VESA 800x600 (Mode 102h)
6      256 color VESA 800x600 (Mode 103h)
7      16 color VESA 1024x768 (Mode 104h)
8      256 color VESA 1280 x 1024 (Mode 107H)

      I      Images
      C      Change Menu Color
      S      Clear Screen
      M      Display Menu
      Q      Quit
```

Commands 1-8 set the Video Mode. The current video mode is always displayed at the bottom of the screen. The default video mode is Mode 12 Hex: 16 Color, 640 columns by 480 rows.

I clears the screen and displays the Image Menu (see below).

- C clears the screen and displays a menu which allows you to select a different color for the menus (press ESC to leave this menu without changing the menu color).
- S clears the VGA screen of image and text.
- M redisplay the menu.
- Q leaves the utility software and returns to DOS.

4.1.3 The Image Menu

PRO AV TEST IMAGES

- T Page of Text
- C Color Bars
- H Chirp
- P Pattern
- I Picture
- A Ramp
- K Chroma Key Chart
- M Menu
- S Clear Screen
- R Return

- T Displays a Page of Text.
- C Displays eight vertical color bars.
- H Displays a Chirp Pattern.
- P Displays a Complex Black and White Pattern.
- I Displays a 16 or 256 color picture (the full picture is seen only in the 1024 x 768 mode; smaller resolutions display the upper left hand corner of the picture).
- A Displays a 16 or 256 grey shades ramp.
- K Displays a 16 or 256 color grid.
- M Redisplay the Image Menu.
- S Clears the screen.
- R Returns to the Main Menu.

4.1.4 Hyperformance Utility Software Error Messages

4.1.4.1 *Not a Legal Command in TEXT MODE*

The Page of Text is the only Image that can be displayed in Text mode. This error message will be displayed if you try to display any of the other Images in Text mode.

4.1.4.2 *Picture8.PCX Not Found!*

Picture8.PCX contains the Picture displayed in the 256 color modes. If this error message occurs, make sure the file PICTURE8.PCX is present in the current directory.

4.1.4.3 *Picture4.PCX Not Found !*

Picture4.PCX contains the Picture displayed in the 16 color modes. If this error message occurs, make sure the file PICTURE4.PCX is present in the current directory.

4.1.4.4 VESA Version n.n VESA CALL FAILED

This error occurs when the VESA driver with the indicated version number has been installed, but a call to the VESA software returns an error code. It indicates an incompatibility between the VESA driver and the VGA card.

4.1.4.5 VESA Driver Not Installed

The utility software uses the VESA TSR in the 1024x768 and 800x600 modes. If your attempt to use these modes results in this error message, make sure you have installed the VESA TSR (see above).

Appendix A - Limited Warranty

FOCUS Enhancements, Inc. warrants this product against defects in materials and workmanship for a period of one (1) year from the date of original purchase.

If you discover a defect, FOCUS Enhancements, Inc. will, at its sole option, repair or exchange the product at no charge to you, provided you contact FOCUS Enhancements, Inc. Technical Support to obtain a Return Material Authorization (RMA) Number and instructions on where and how to obtain repair. Note that a copy of the bill of sale bearing the FOCUS Enhancements, Inc. serial numbers as proof of date of original purchase is required for each product returned for warranty service. Before returning product, remove all non-FOCUS Enhancements, Inc. RAM, accessories, and options. FOCUS Enhancements, Inc. cannot be liable for the return or care of any non-FOCUS Enhancements, Inc. products, nor accept responsibility for loss or damage of product in transit.

This warranty does not apply if the product has been damaged by accident, installation or removal of product, abuse, misuse, misapplication, accident, neglect, fire, water, lightning, or other acts of nature, failure to follow supplied instructions; has been modified, repaired or undergone attempted repair by unauthorized personnel without the written consent of FOCUS Enhancements, Inc.; has a serial number that has been removed, modified, or defaced. FOCUS Enhancements, Inc. reserves the right to use re-manufactured, refurbished, or used parts and components in making warranty repairs.

FOCUS Enhancements, Inc. products are designed to work with Windows and MacOS computers. Certain features of third-party software or hardware designed for the host system may not be available when used with this product. Accordingly, FOCUS Enhancements, Inc. does not warrant or represent that all third-party software or hardware will function error-free when used in conjunction with this FOCUS Enhancements, Inc. product.

THIS WARRANTY IS IN LIEU OF ALL OTHER WARRANTIES, WHETHER ORAL OR WRITTEN, EXPRESS OR IMPLIED. ALL EXPRESS AND IMPLIED WARRANTIES OF MERCHANTABILITY AND FITNESS FOR A PARTICULAR PURPOSE, ARE LIMITED IN DURATION TO THE WARRANTY PERIOD. NO WARRANTIES, EXPRESS OR IMPLIED WILL APPLY AFTER THIS PERIOD. FOCUS ENHANCEMENTS, INC. SHALL NOT BE LIABLE FOR ANY LOST PROFITS, DAMAGE TO OTHER PROPERTY CAUSED BY A DEFECT IN THIS PRODUCT, DAMAGES BASED UPON INCONVENIENCE, LOSS OF USE OF THE PRODUCT, LOSS OF TIME, COMMERCIAL USE, INCIDENTAL AND/OR CONSEQUENTIAL DAMAGES FOR THE BREACH OF ANY EXPRESS OR IMPLIED WARRANTY, INCLUDING DAMAGE TO PROPERTY AND, TO THE EXTENT PERMITTED BY LAW, DAMAGES FOR PERSONAL INJURY, EVEN IF FOCUS ENHANCEMENTS, INC. HAS BEEN ADVISED OF THE POSSIBILITY OF SUCH DAMAGES.

Some states do not allow the inclusion or limitation of incidental or consequential damages or limitations on how long an implied warranty lasts, so the above limitation or exclusion may not apply to you. This warranty gives you specific legal rights, and you may have other rights, which vary, from state to state.

Appendix B - Hyperformance Utility Software License

FOCUS Enhancements Corporation grants the user a 99 year license to use and reproduce the Hyperformance Utility Software. No restrictions in copying or using the software or its reproduced images are implied except that any video taped reproduction of any image developed or displayed by the Hyperformance Utility Software must be reproduced using a FOCUS Enhancements Pro AV 1600 product.

Appendix C – Genlock

All versions of the Pro AV 1600 can Genlock to a black burst, or active video external reference signal. Our usage of the word Genlock is the usage understood by professional Television Engineers. The Pro AV 1600 will lock Vertically, Horizontally and in color phase to the external reference signal. All Overlay, Chroma-Key, mixing functions, etc. must be accomplished by additional devices.

The suggested way to align Genlock is as follows:

Make sure that the Pro AV 1600 provides a properly aligned picture with respect to an ordinary television raster. (Since you have control over Horizontal and Vertical Size and Position, all 4 of these parameters must be properly aligned with a television raster before attempting Genlock).

Connect the Genlock reference signal into the Genlock BNC connector. If you wish to loop through, insert a BNC “T” connector to the input, and connect the other Genlock connector to the next device that you want to provide Genlock reference to. If the Pro AV 1600 is the last device in the configuration, select the Genlock Termination "On" from the Front Panel or RS-232/422 Communication. Otherwise, make certain that you select Genlock Termination "Off." The 2 Genlock connectors are directly connected with no buffering.

Adjust the Genlock Horizontal Position (from the application software Graphical User Interface) for correct position of the converted video signal at the mixing point.

Adjust the Genlock Color Phase (from the application software Graphical User Interface) for the correct color phase of the converted video signal at the mixing point.

Appendix D - Component output

All versions of the Pro AV 1600 support two user selectable forms of component output. The Pro AV 1600 is factory configured for Betacam component (Y, R-Y, B-Y) and RGB (without 7.5 IRE units of video setup). In addition, component output synchronization may be provide as a separate, composite sync signal (4 wire) or as composite sync signal on the green output (3 wire). Other amplitudes of component output (i. e. M II) are available by special order.

The component out daughter board isn't required. Should you not be using Component, you can save a slot by unplugging the ribbon cable from the ProAV 1600PCI board.